

# FMS-405A

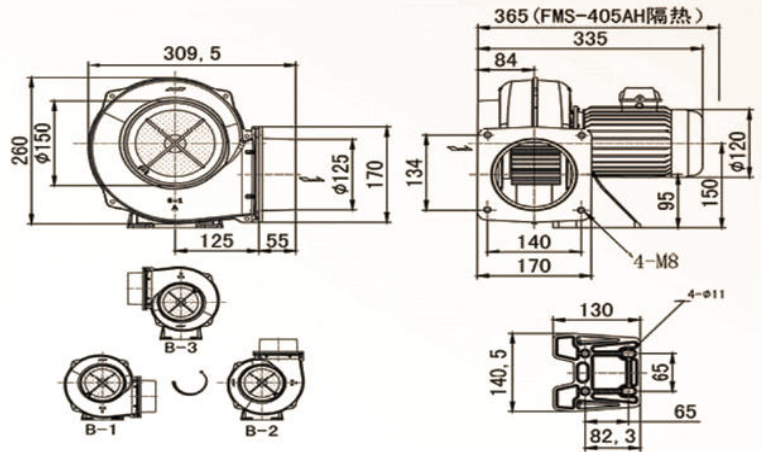

FMS-405A

## FMS STRUCTURE DIAGRAM

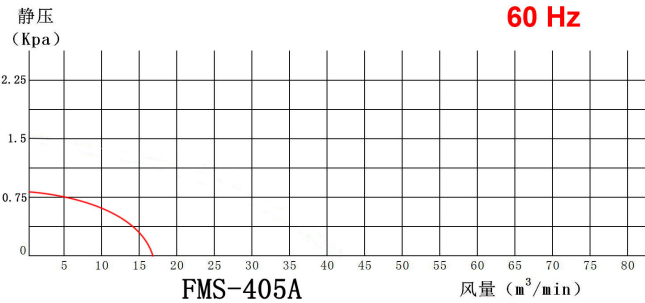
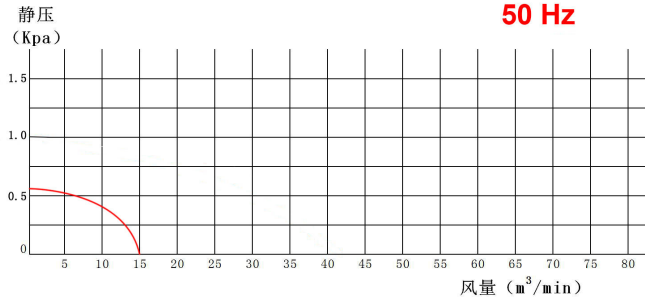
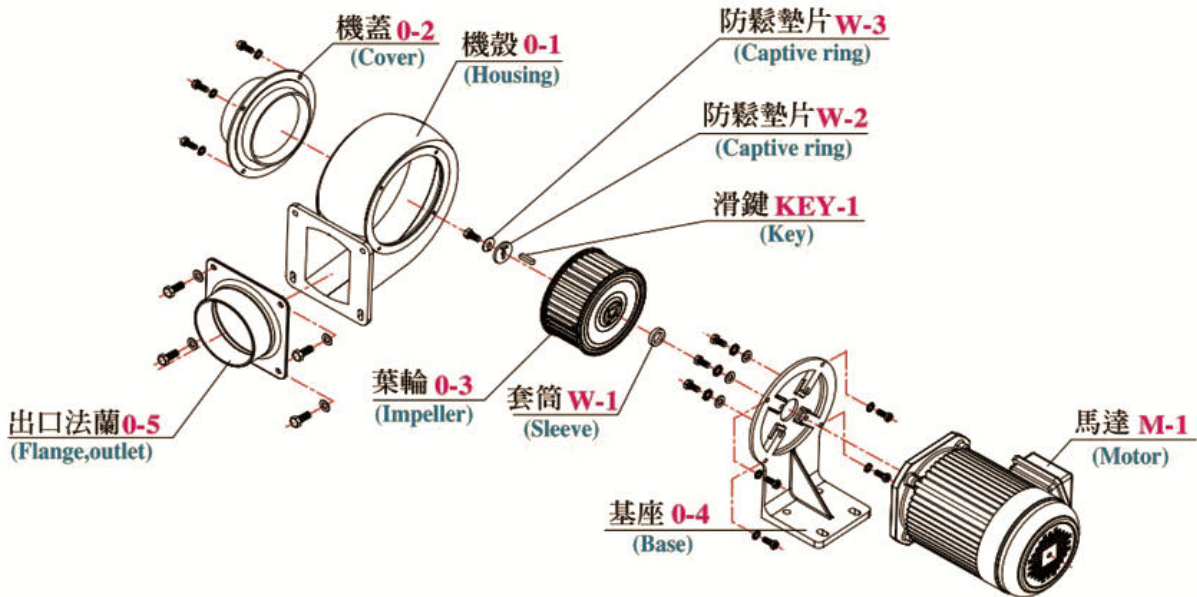

## FMS SERIES SPECIFICATION SHEET

风机型号 Type	相数 Phase	功率 Power (KW)	额定电压 Voltage (V)	额定电流 Current (A)	最大静压 (吐出) Vacuum/Pressure (max) (KPa)	最大风量 (吐出) Air Flow (max) (m3/min)	进出口 口径 In/Out (mm)	噪音 Noise Level (dB)	重量 Weight (Kg)
FMS-202A	1 ~ 3 ~	0.2	220 220 / 380	1.5 1.1 / 0.9	0.5/0.8	8/10	IN 125 OUT 100	60/65	6
FMS-405A	1 ~ 3 ~	0.4	220 220 / 380	2.5 1.9 / 1.2	0.6/0.8	15/17	IN 150 OUT 125	65/70	8
FMS-751A	1 ~ 3 ~	0.75	220 220 / 380	5 3 / 1.9	0.7/1	23/25	IN 200 OUT 150	70/75	11
FMS-1502	1 ~ 3 ~	1.5	220 220 / 380	9 5.5 / 3.5	0.9/1.3	29/37	IN 200 OUT 200	75/80	21
FMS-1503	3 ~	2.2	220 / 380	8/5	1.1/1.7	39/47	IN 200 OUT 200	75/80	24