

MS-405A

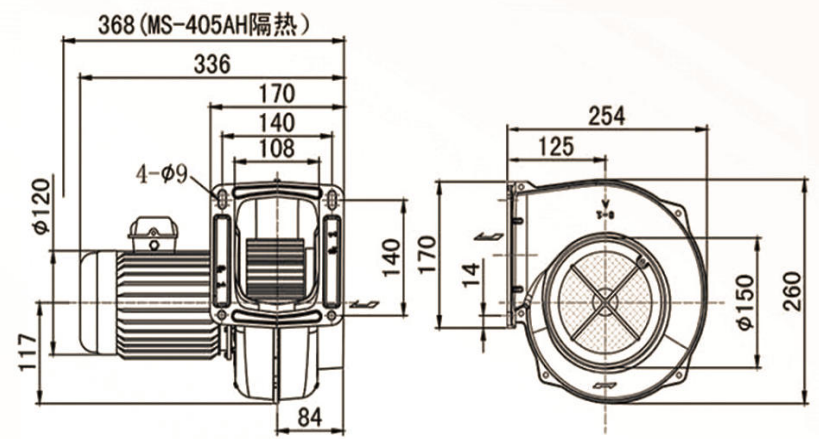

MS-405A

MS STRUCTURE DIAGRAM

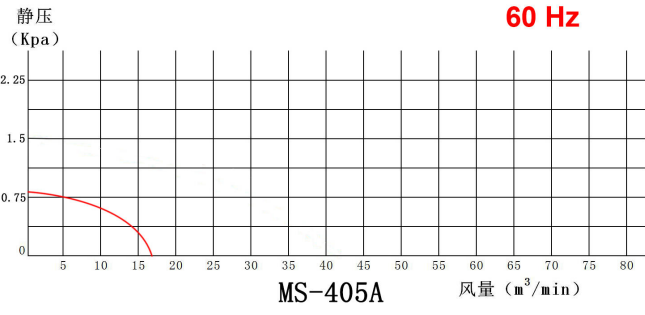
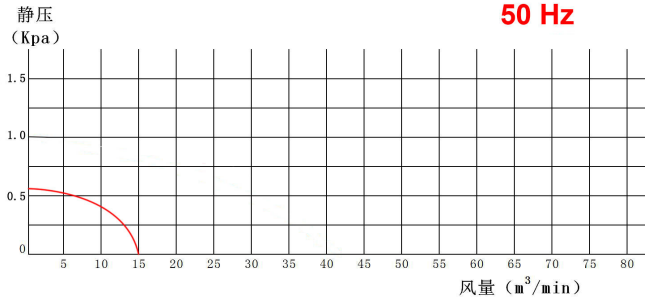
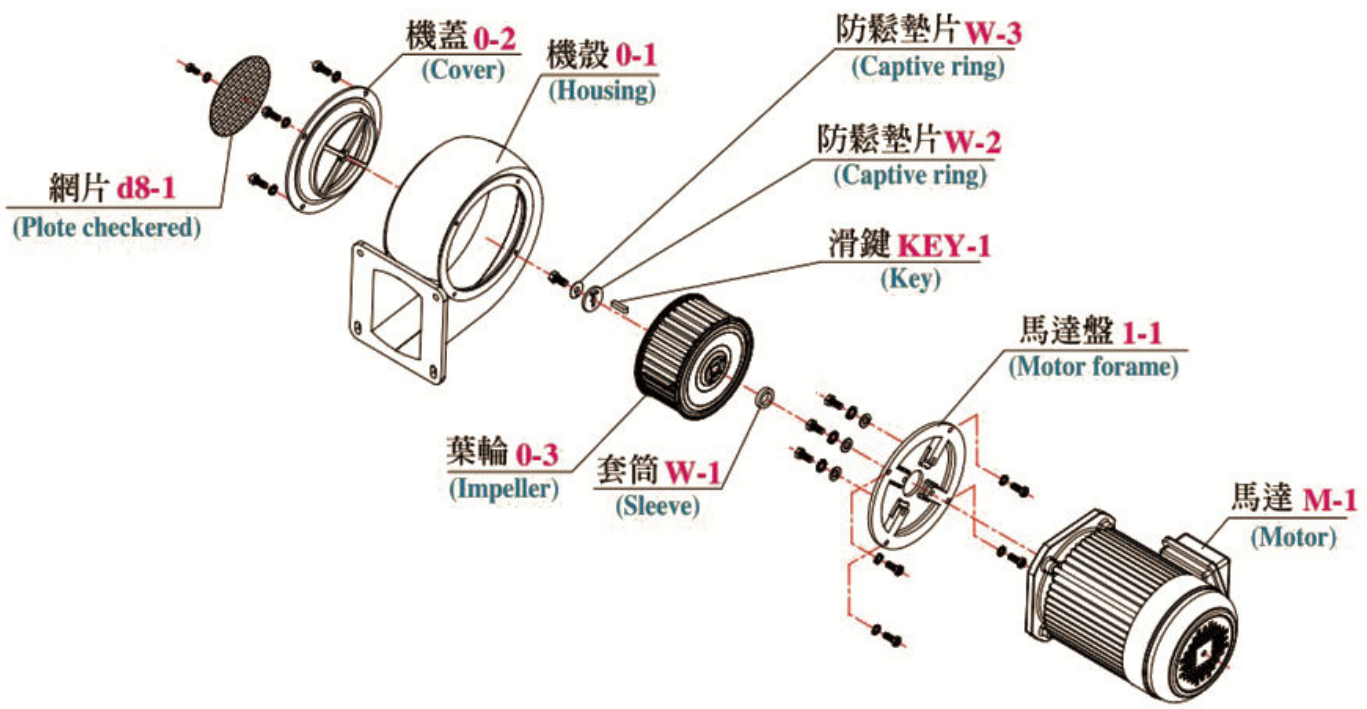

风机型号 Type	相数 Phase	功率 Power (KW)	额定电压 Voltage (V)	额定电流 Current (A)	最大静压 (吐出) Vacuum/Pressure (max) (KPa)	最大风量 (吐出) Air Flow (max) (m3/min)	出入口 口径 In/Out (mm)	噪音 Noise Level (dB)	重量 Weight (Kg)
MS-202A	1 ~	0.2	220	1.5	0.5/0.8	8/10	IN 125	60/65	6
	3 ~		220 / 380	1.1 / 0.9			OUT 95*100		
MS-405A	1 ~	0.4	220	2.5	0.6/0.8	15/17	IN 150	65/70	8
	3 ~		220 / 380	1.9 / 1.2			OUT 110*135		
MS-751A	1 ~	0.75	220	5	0.7/1	23/25	IN 200	70/75	11
	3 ~		220 / 380	3/ 1.9			OUT 135*160		
MS-1502	1 ~	1.5	220	9	0.9/1.3	29/37	IN 0	75/80	21
	3 ~		220 / 380	5.5/ 3.5			OUT		
MS-1503	3 ~	2.2	220 / 380	8/5	1.1/1.7	39/47	IN 0 145*170	75/80	24
							OUT 125		