

# PF200-5

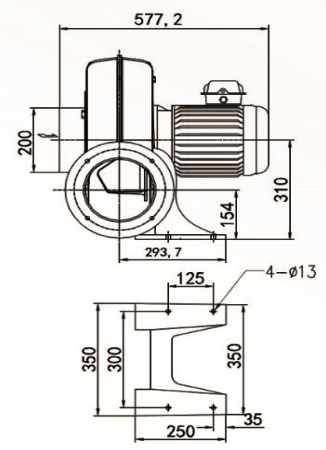

PF200-5

## PF STRUCTURE DIAGRAM

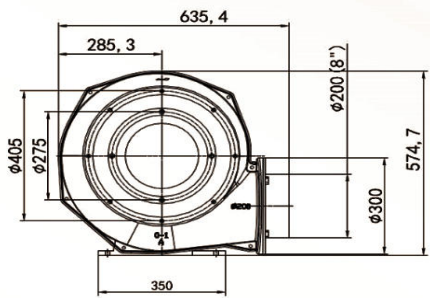
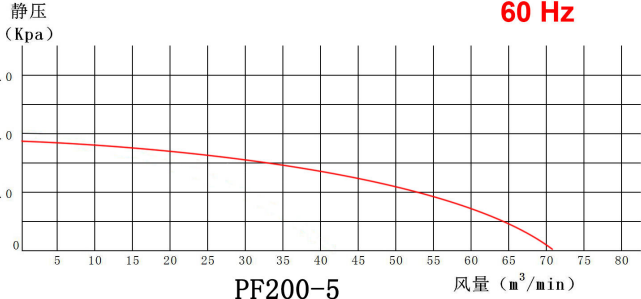
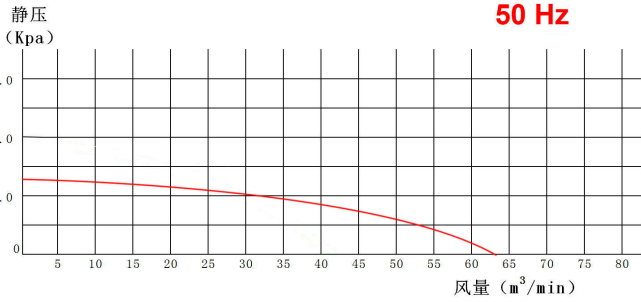
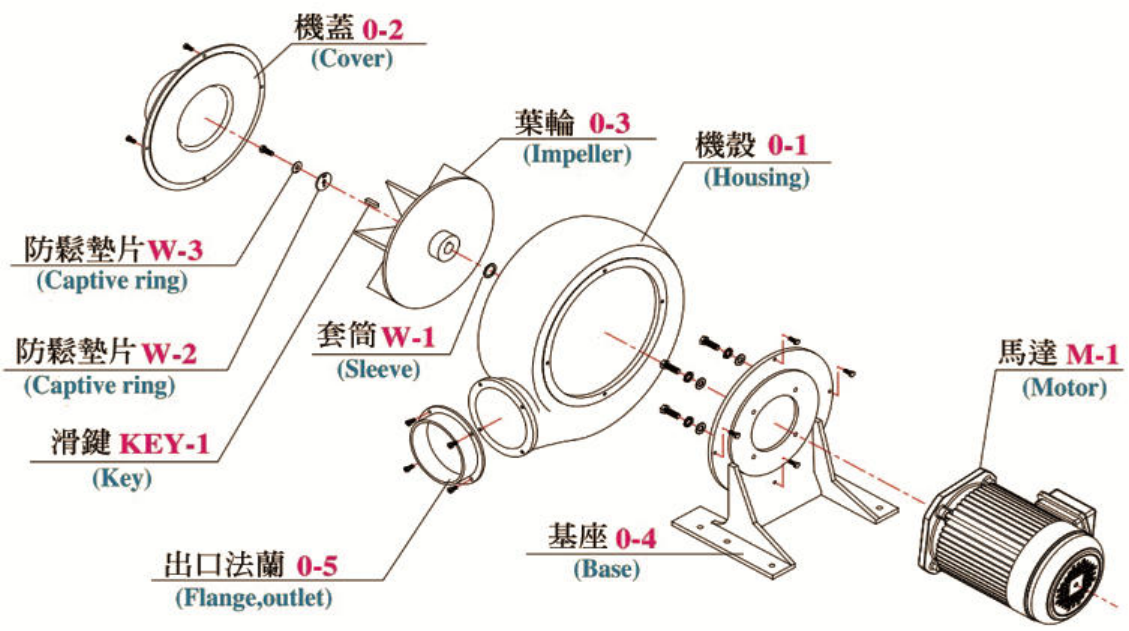

## PF SERIES SPECIFICATION SHEET

风机型号 Type	相数 Phase	功率 Power (KW)	额定电压 Voltage (V)	额定电流 Current (A)	最大静压 (吐出) Vacuum/Pressure (max) (KPa)	最大风量 (吐出) Air Flow (max) (m3/min)	出入口 口径 In/Out (mm)	噪音 Noise Level (dB)	重量 Weight (Kg)
PF75-02	1 ~	0.2	220	1.5	0.5/0.7	5/6	IN 100	50/62	10
	3 ~		220 / 380	1.1 / 0.9			OUT 100		
PF100-05	1 ~	0.4	220	2.5	1/1.2	8/10	IN 100	56/70	13
	3 ~		220 / 380	1.9 / 1.2			OUT 100		
PF125-1	1 ~	0.75	220	5	1.1/1.4	14/17	IN 125	65/80	17
	3 ~		220 / 380	3 / 2.0			OUT 125		
PF150-2	1 ~	1.5	220	9	1.3/1.9	28/33	IN 150	75/90	30
	3 ~		220 / 380	5.5 / 3.5			OUT 150		
PF150-3	3 ~	2.2	220 / 380	8/5	1.6/2.5	33/37	IN 150	75/93	33
PF200-5	3 ~	3.7	220 / 380	13 / 7.5	2.6/3.8	63/71	IN 200	80/100	49
							OUT 200		